

Two Drawer Adjustable Table Instructions Manual

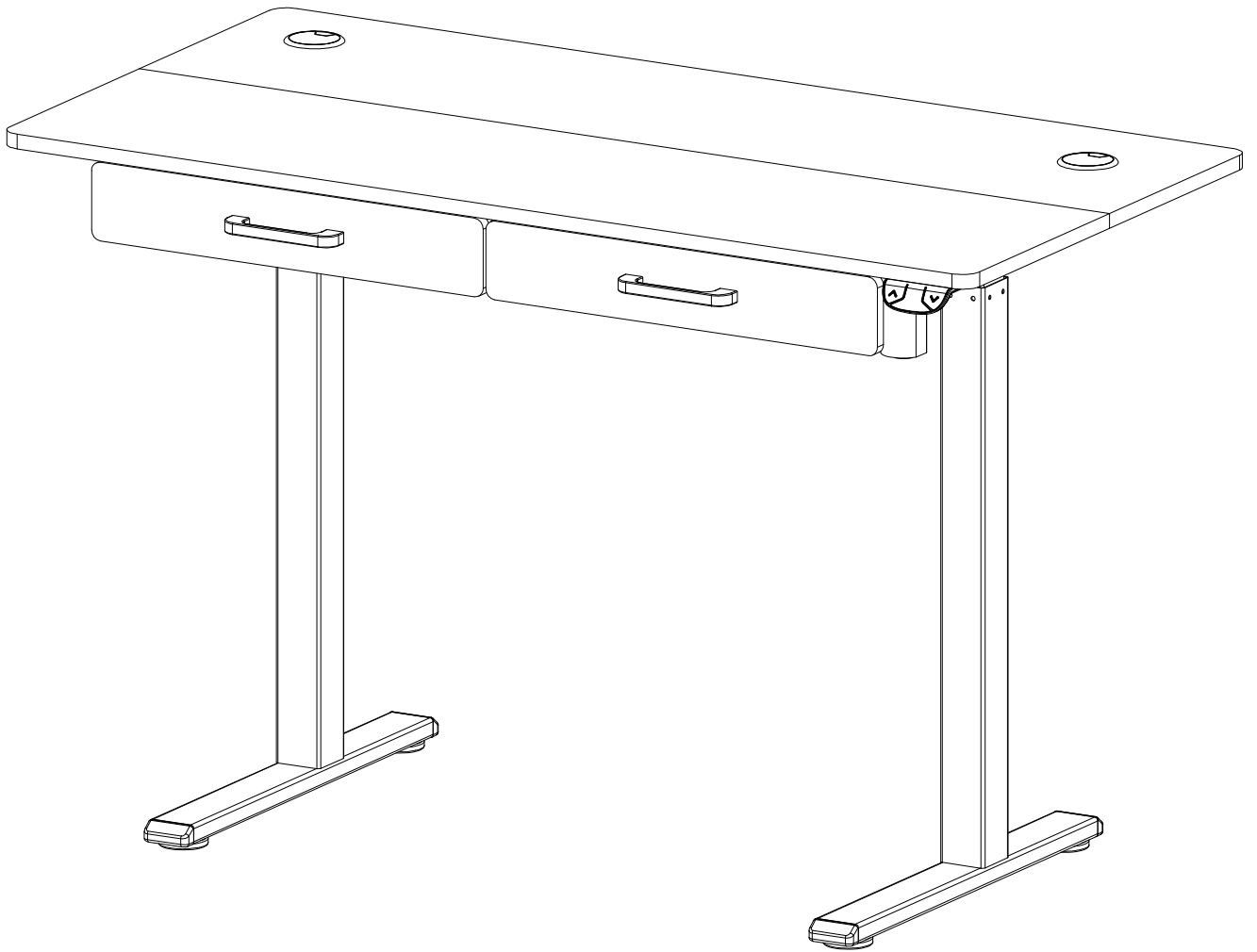

A x2

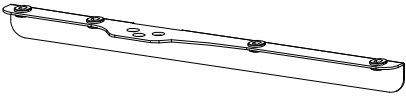

B x1

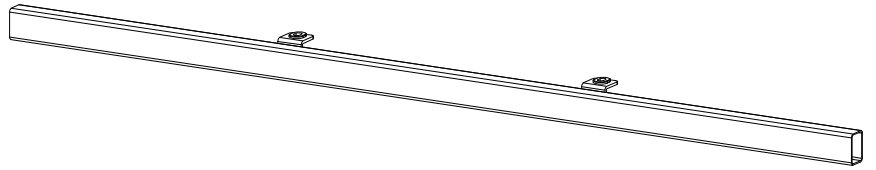

C x1

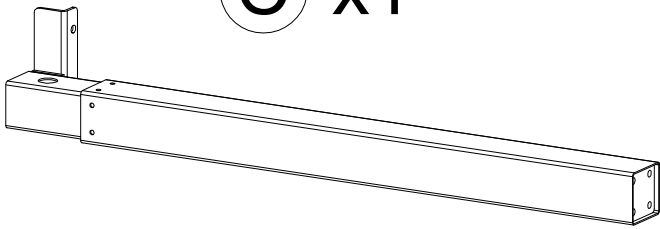

D x1

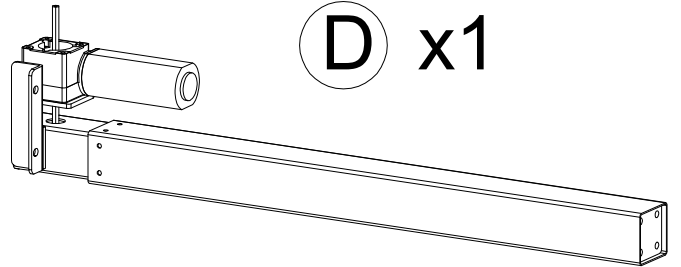

E x2

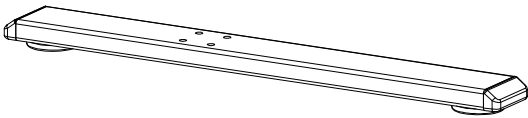

F x1



G x3

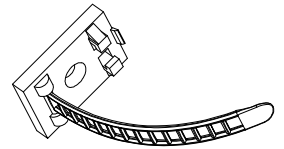

H x1

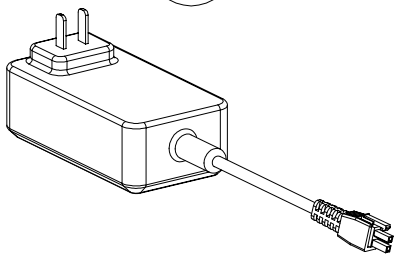

I x4



J₁ x1



J₂ x1

Component pre
installation screws



K x3



L x2



M₁ x1

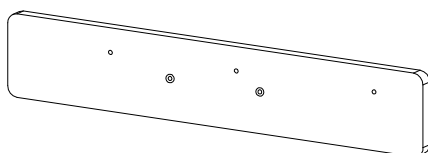

M₂ x1

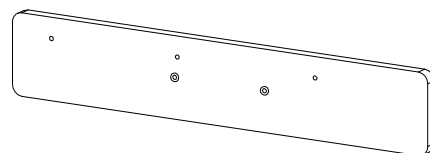

N₁ x1

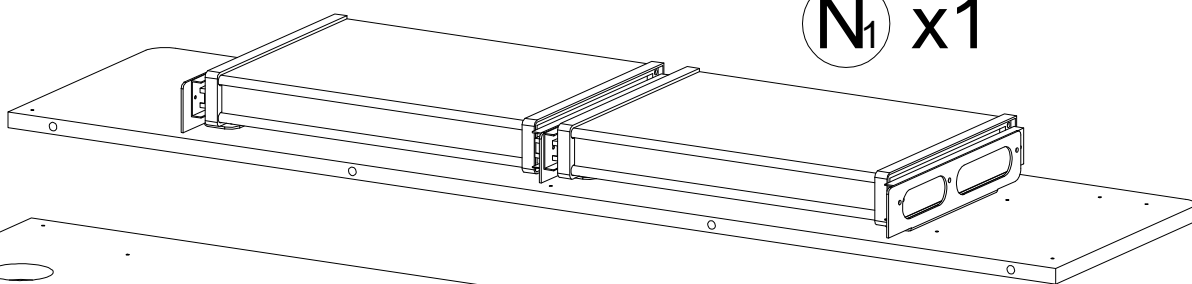

N₂ x1

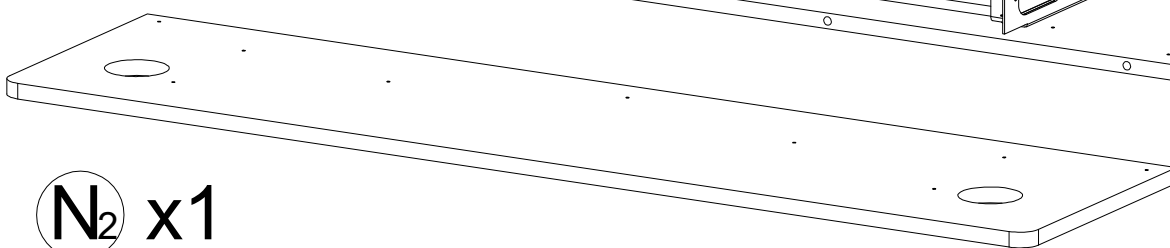

O x12

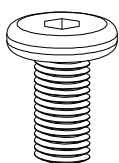

M6x12

P x6

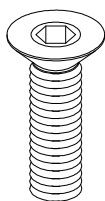

M6x20

Q x18

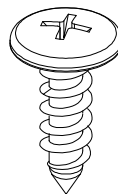

ST5x14

R x4

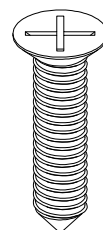

ST4x20

S x6

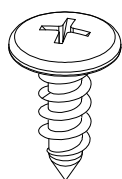

ST4x12

T₁ x1

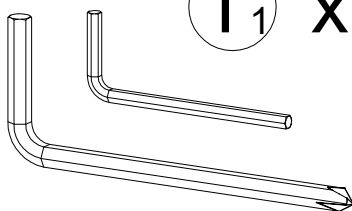

T₂ x1

⓪ x12 Ⓟ x6 Ⓠ x18 Ⓡ x4 Ⓢ x6

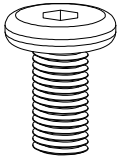

M6x12

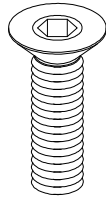

M6x20

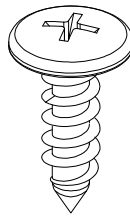

ST5x14

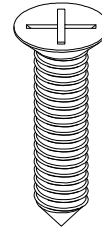

ST4x20

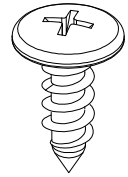

ST4x12

Please note we included 1 extra spare screw for each screw in the package

O x4

T₂

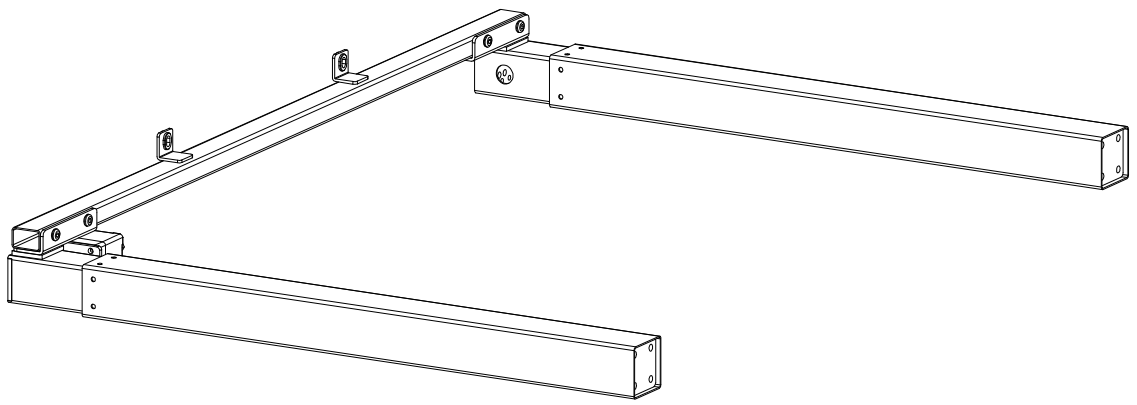
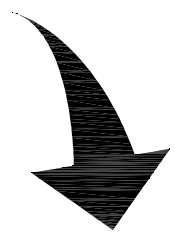
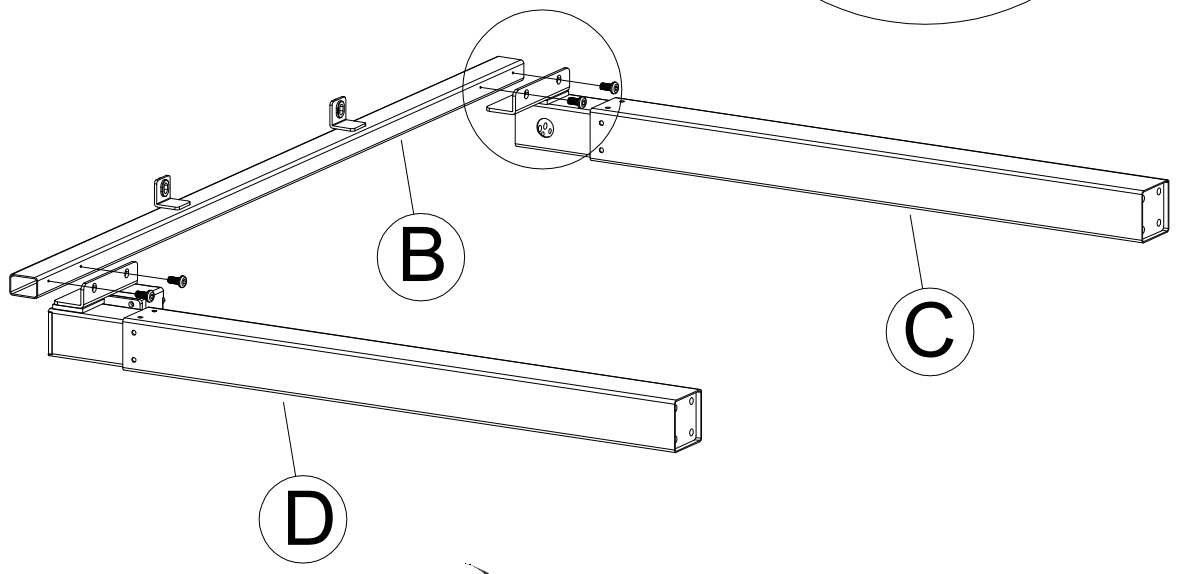
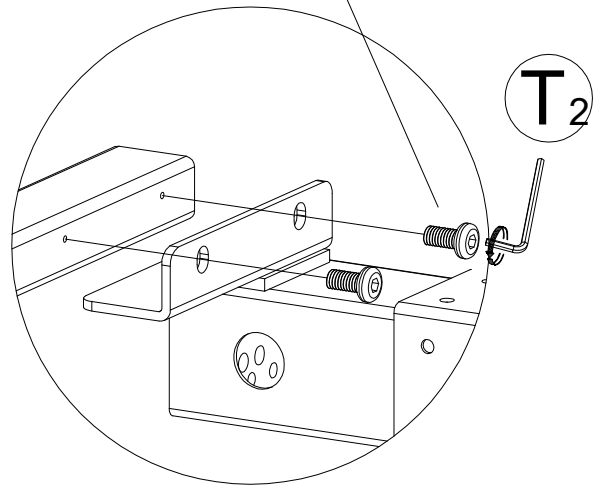

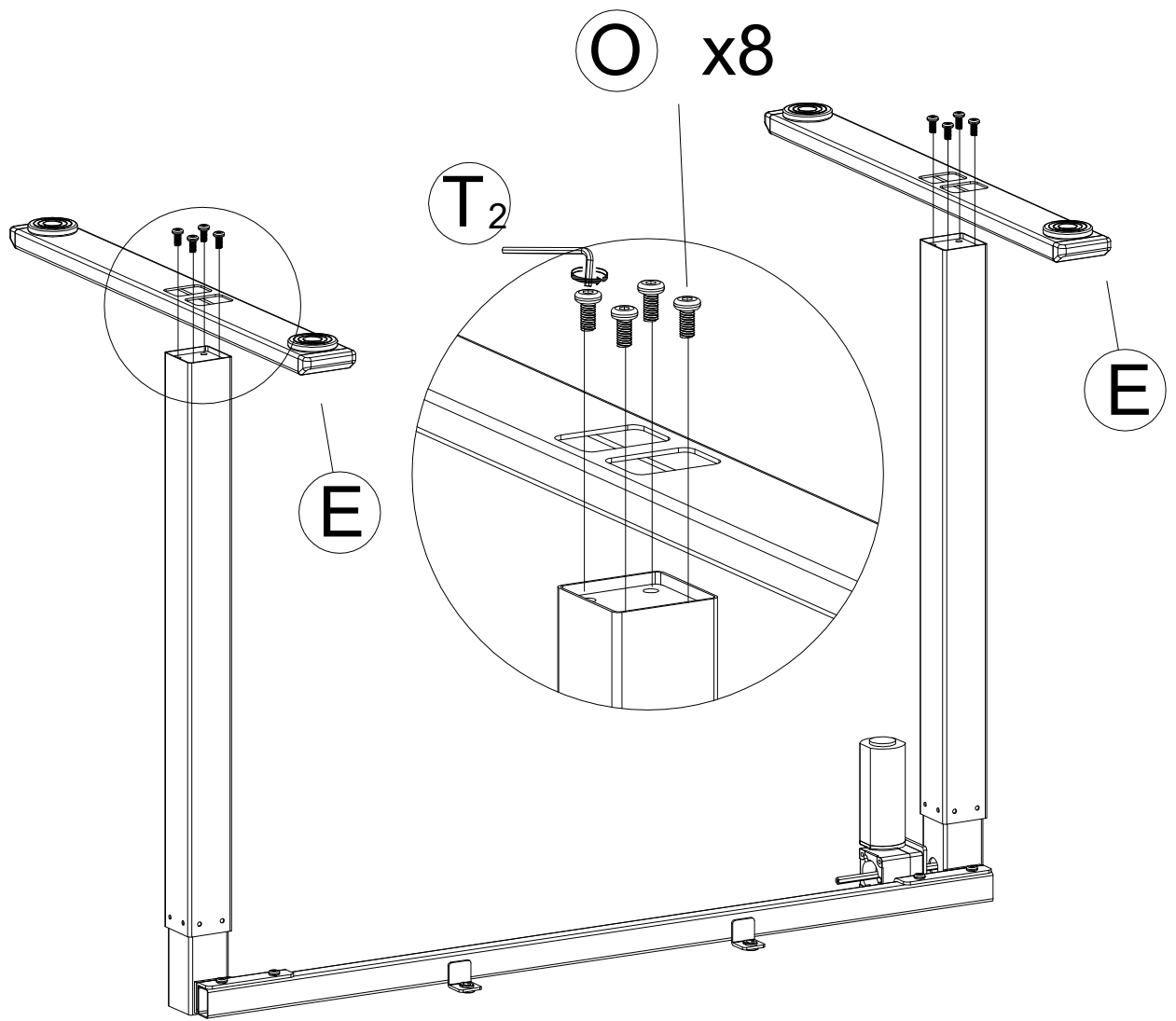

Please note this side is the longer end

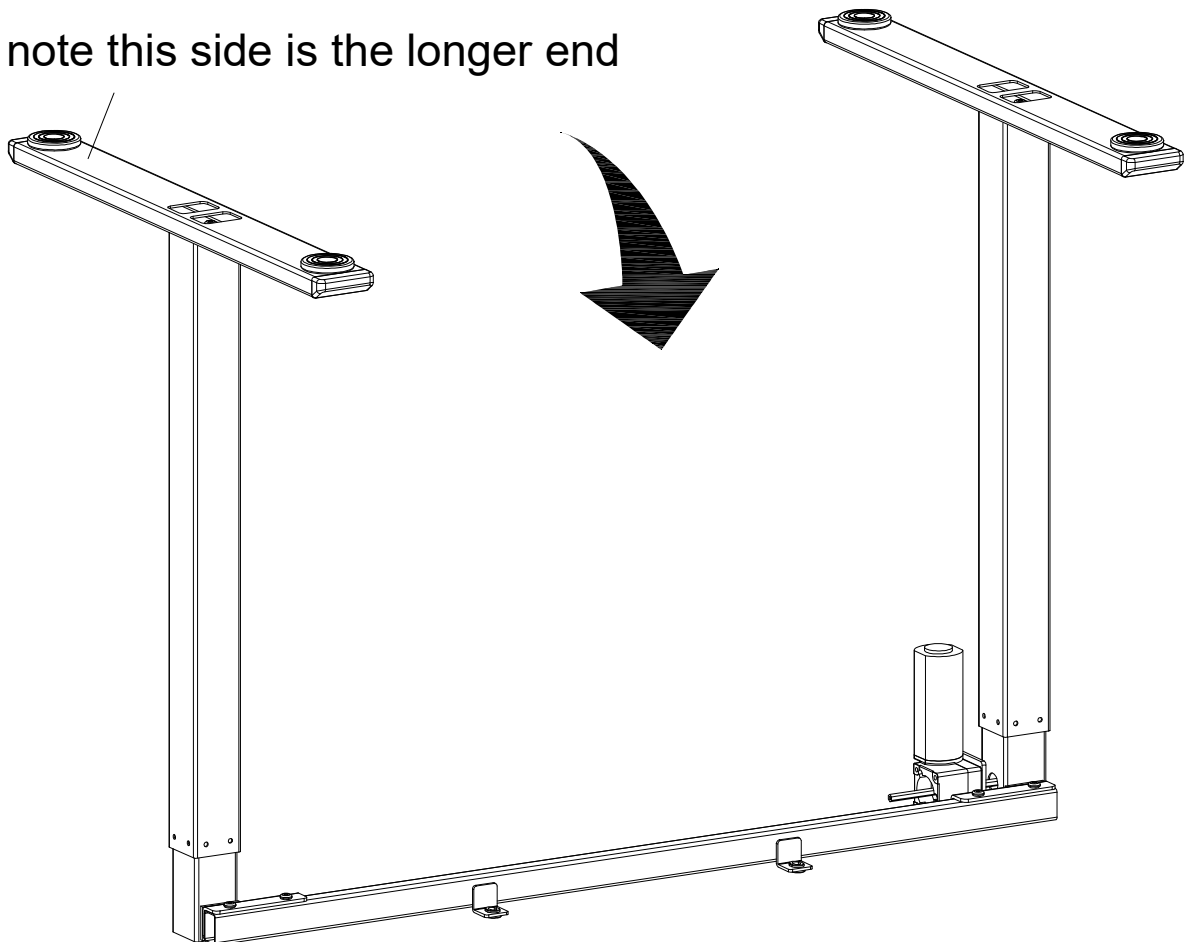

Please note this side is the longer end

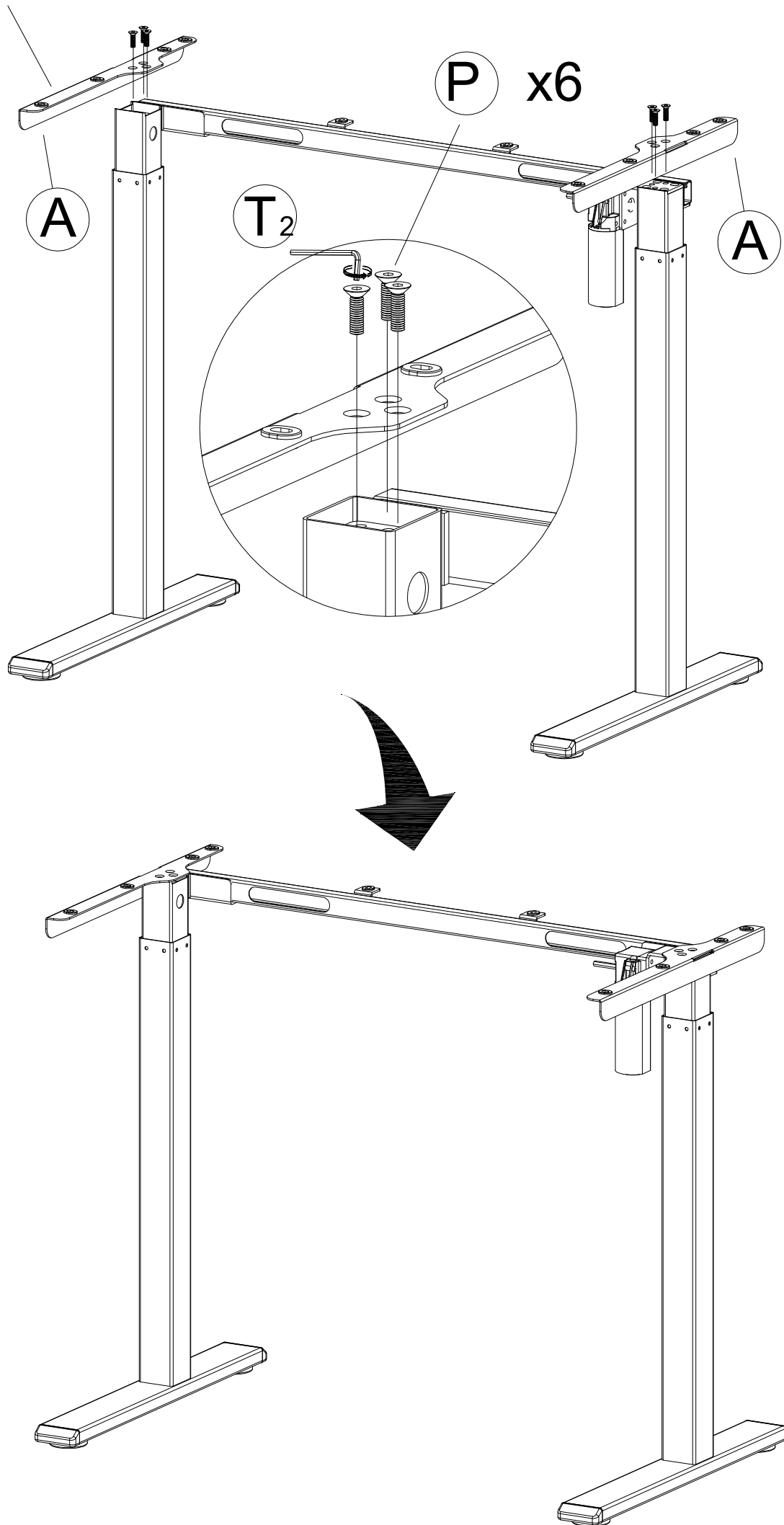

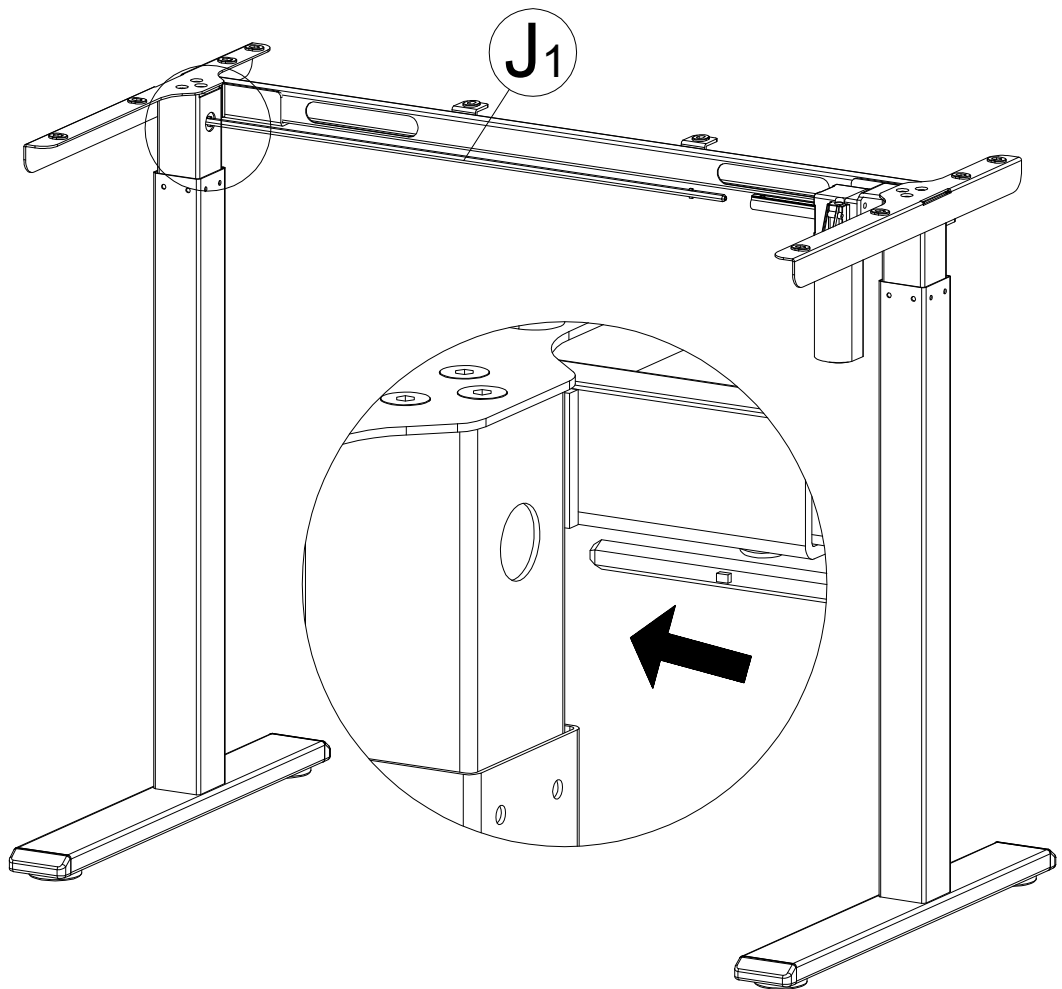
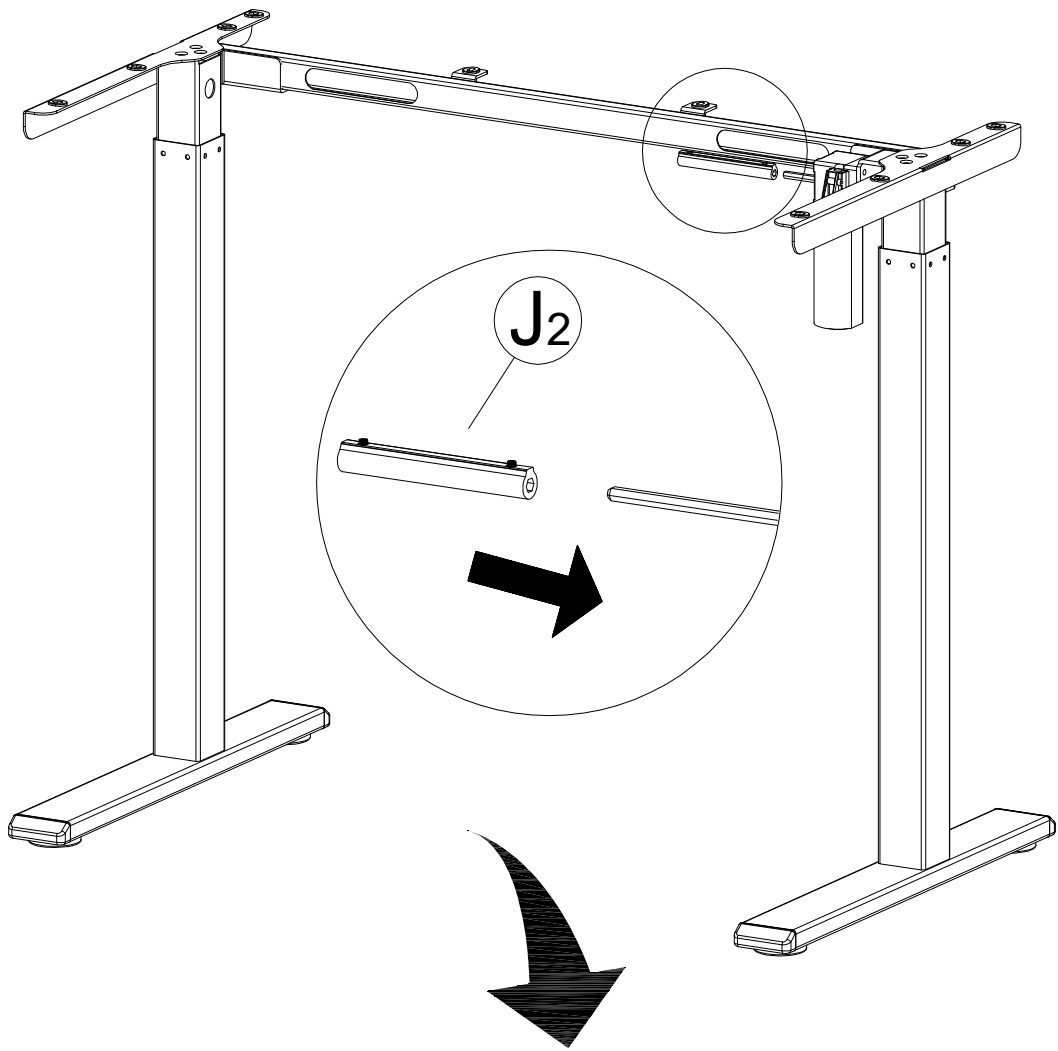

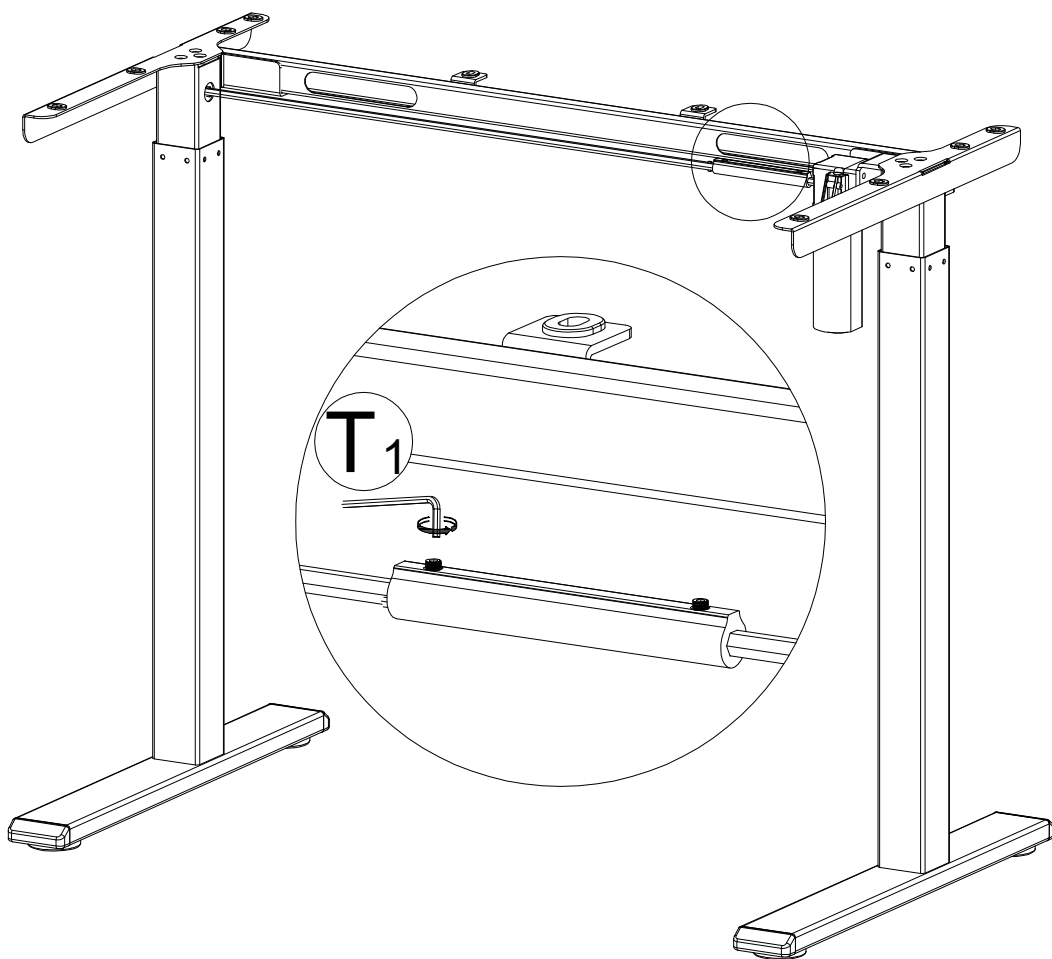
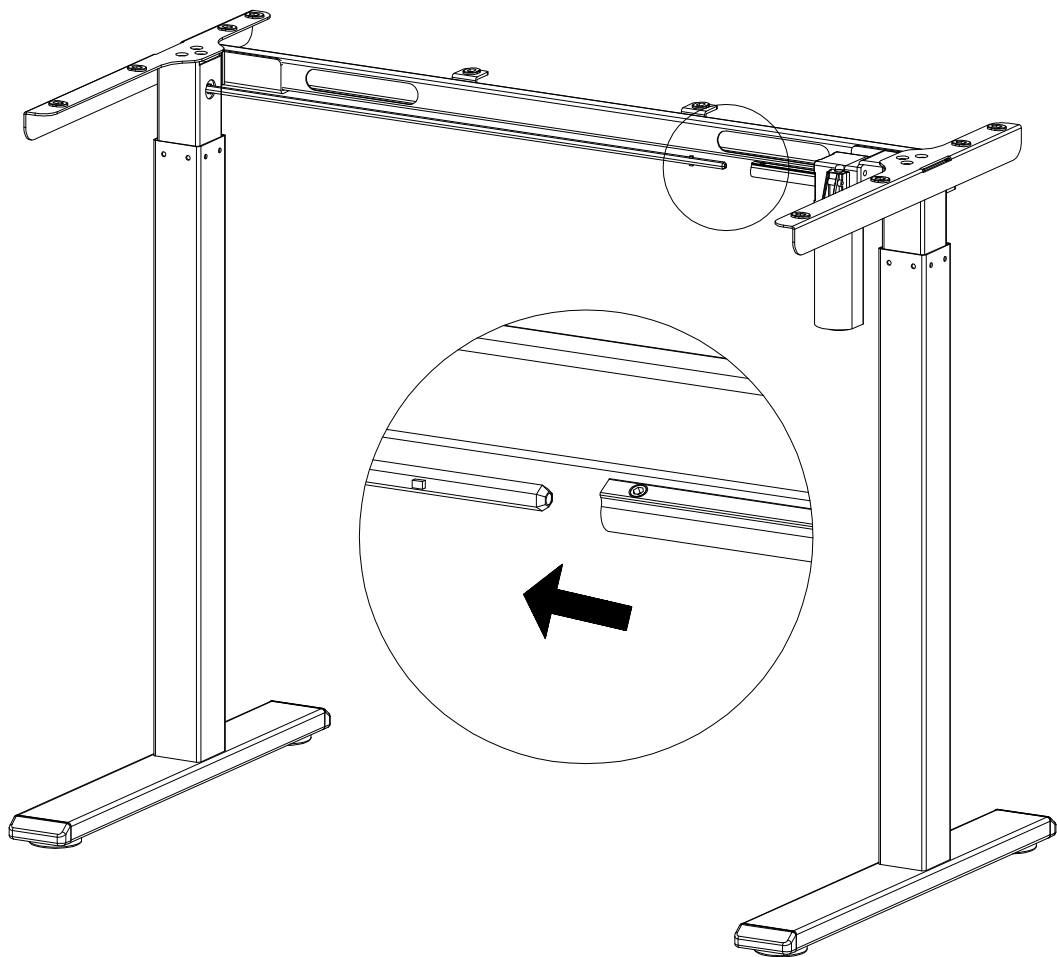

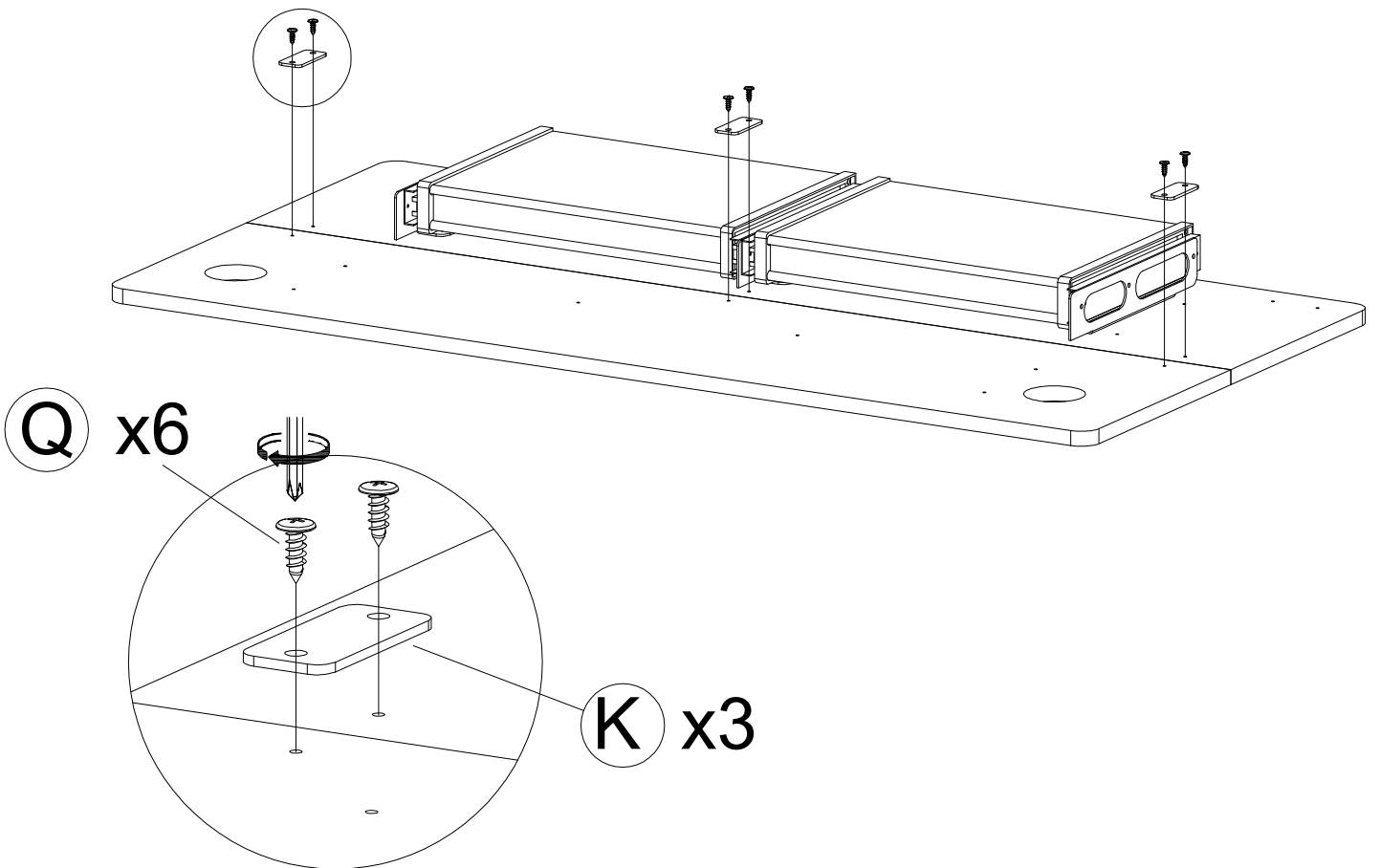
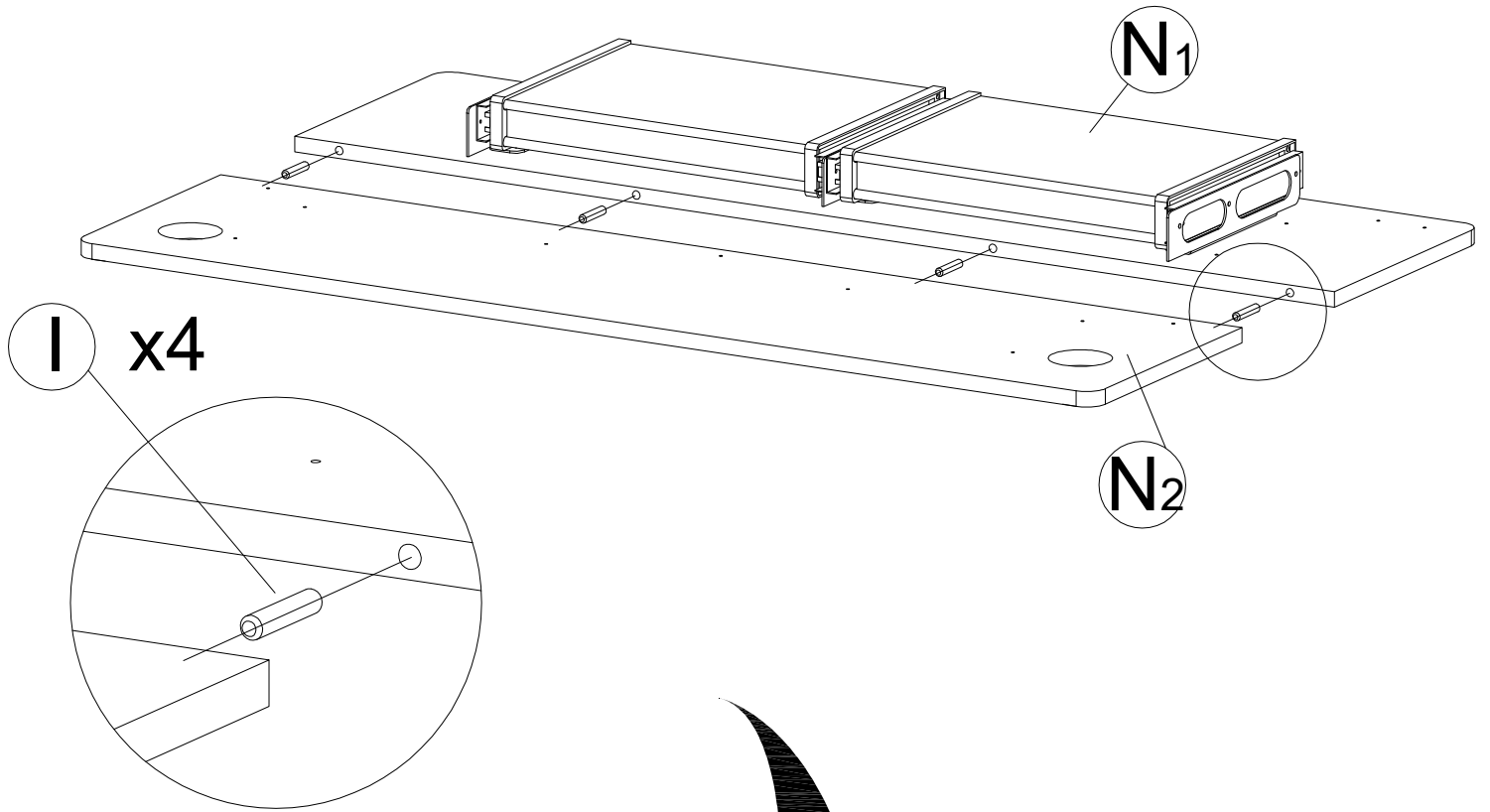

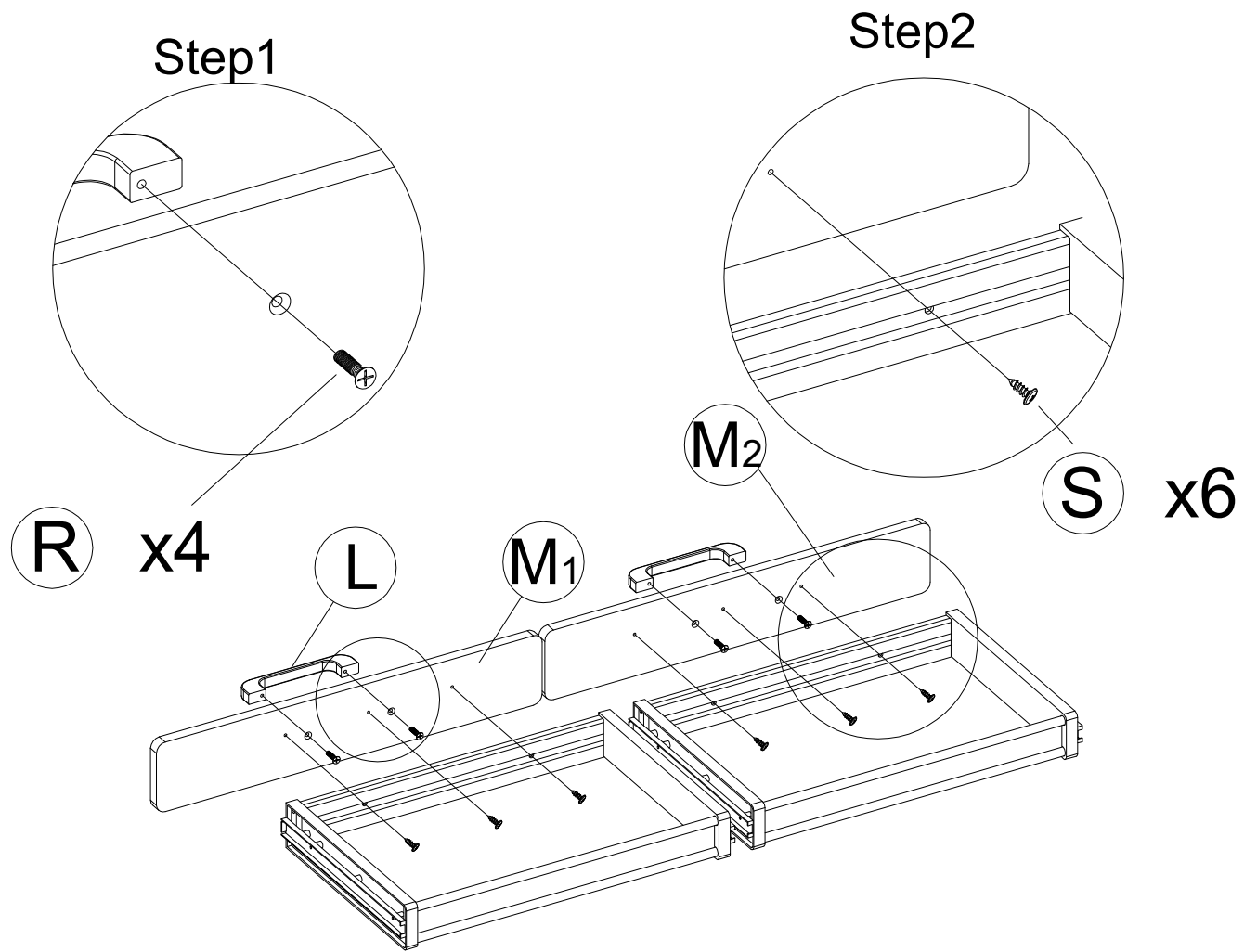

Please note the drawers are placed in this configuration.

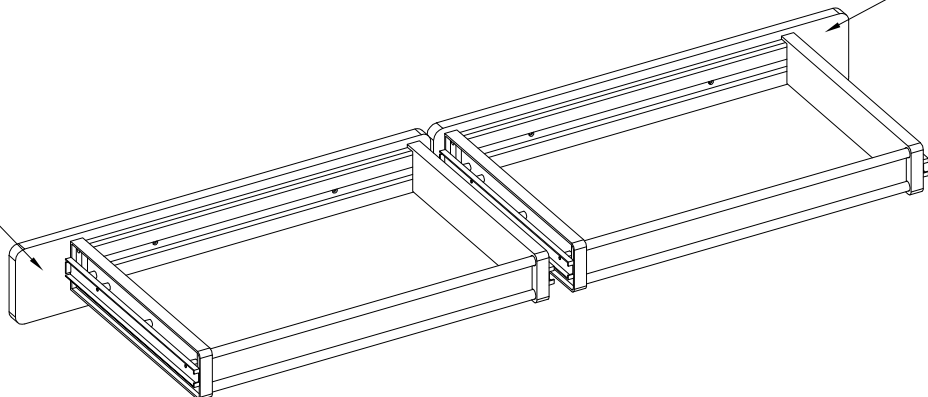

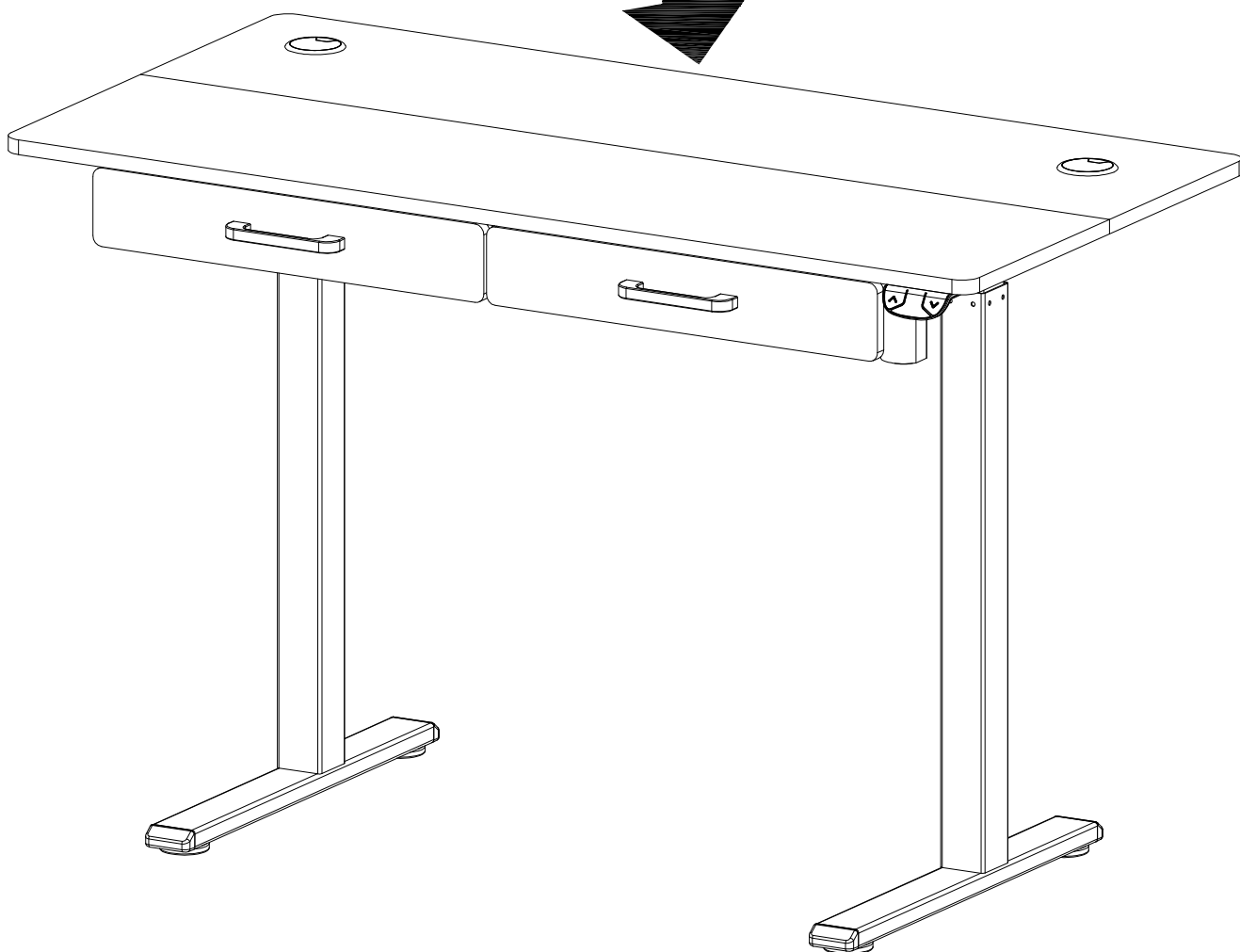
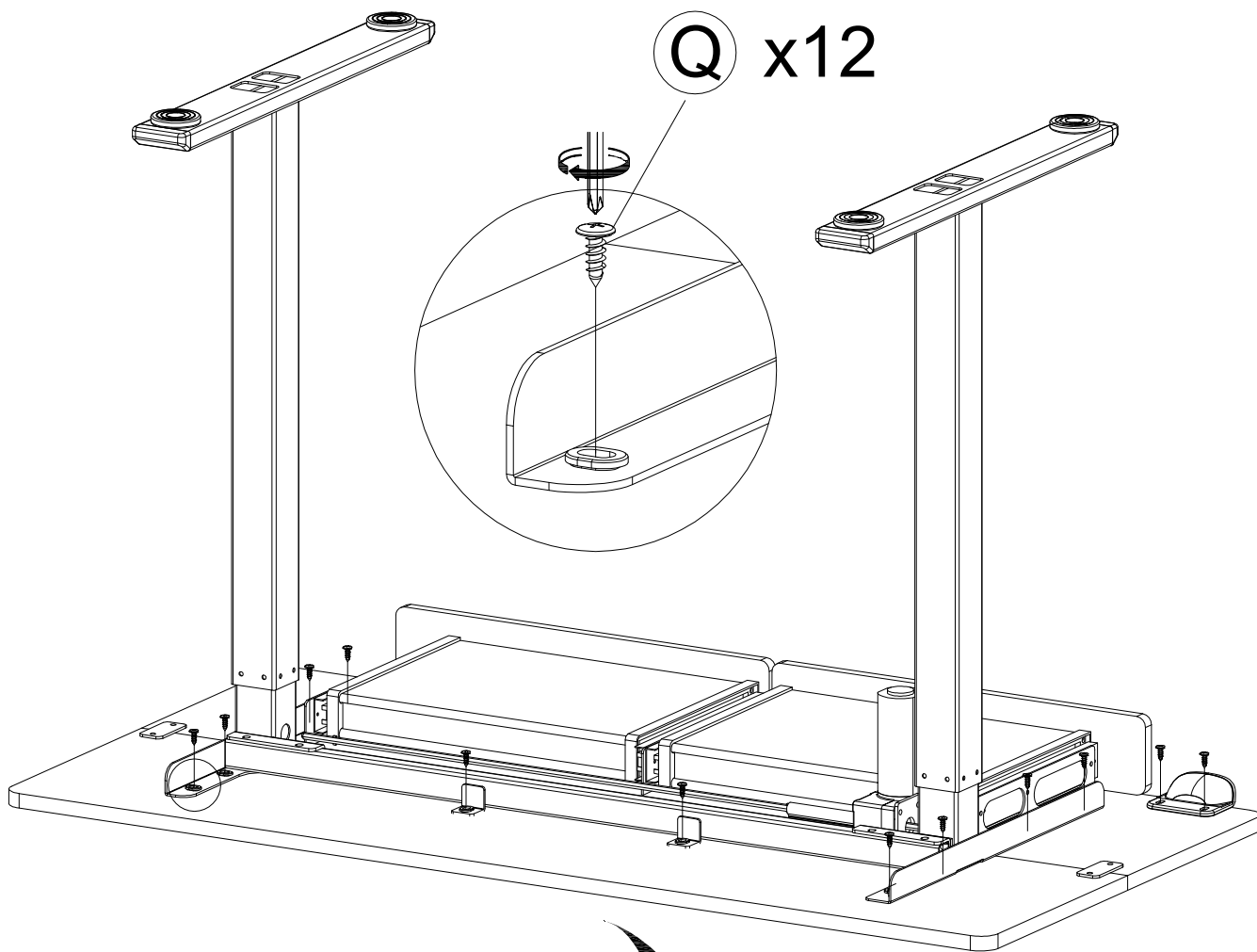

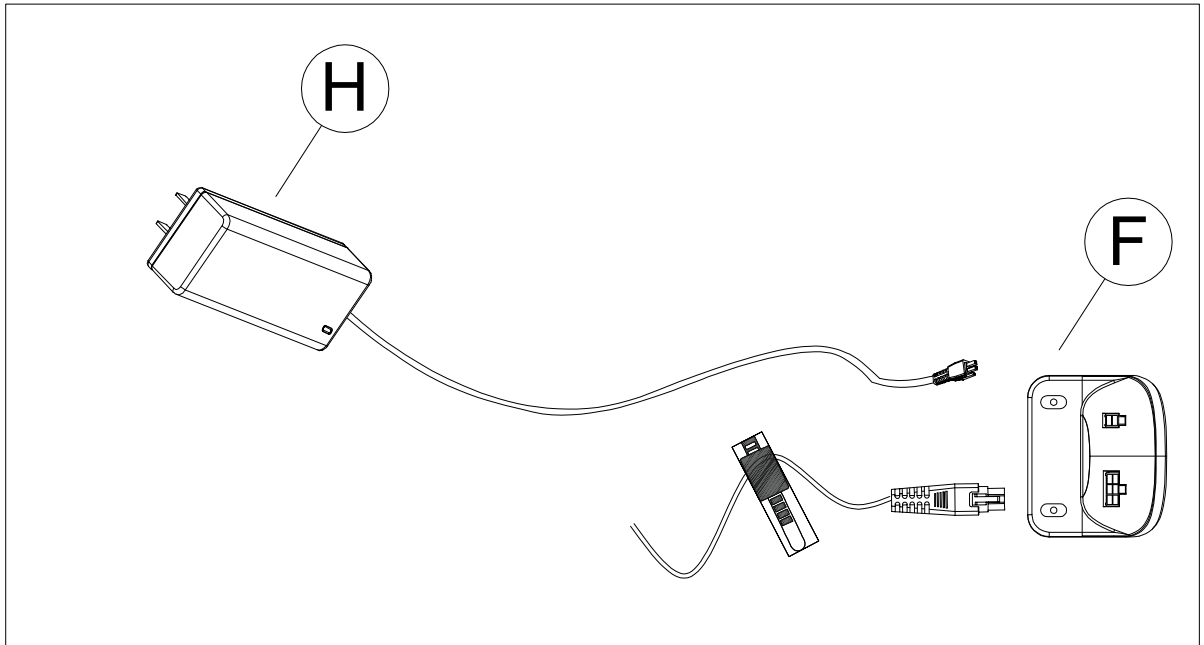
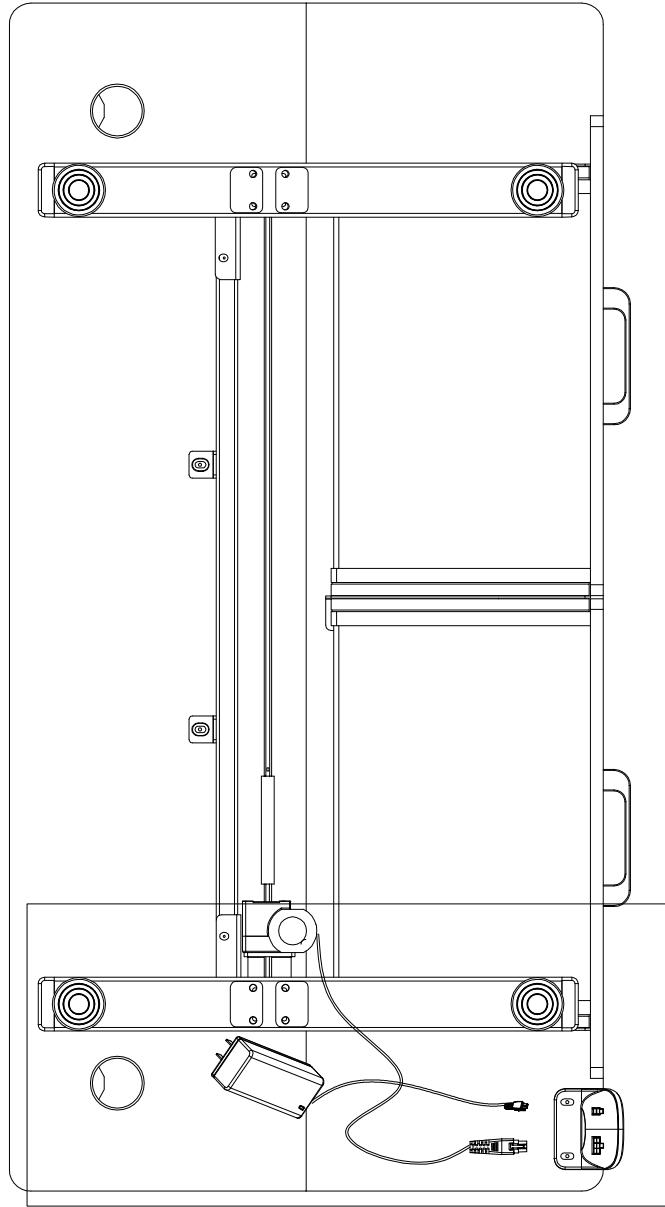

Introduction to the Manual Controller Interface

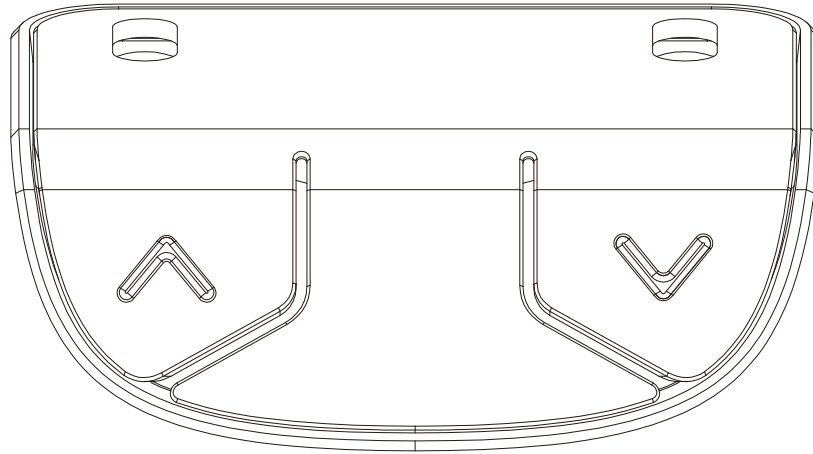

Monitor

Up: Up key

Down: Down key

Up and down key operation

When the "up" button is held , the desktop runs upwards until it reaches its highest point.

When the "down" button is held , the desktop runs downwards until it reaches its lowest point.

When pressing the "up" or "down" button briefly, the desktop will gradually move to achieve the desired height .

After holding the "up" or "down" button for 3 seconds, the desktop will automatically run to the "highest point" or "lowest point" position.

Zero position reset

After pressing the "up" and "down" keys for 3 seconds, wait for the controller's indicator to flash "---", then release the "up" and "down" keys to enter the reset mode. The desktop will automatically run downwards, and when it reaches the lowest point, the desktop will automatically run upwards to a fixed position, and the reset process is completed.

Error Code Table

Error	Illustrate	Handling method
E01	Motor not connected	Press the up or down button again to see if the error persists. If so, please check the connection wire of the column motor
E02	Motor overcurrent	Press the up or down button again to see if the error persists. If so please reduce the load
E03	Motor Hall fault	Press the up or down button again to see if the error persists If so, please check the connection to the motor
E04	Abnormal main power supply	Unable to eliminate power failure, replace power supply
E05	Abnormal motor current	Unable to eliminate power failure and needs to be returned to the factory
E06	Motor power device failure	Unable to eliminate power failure and needs to be returned to the factory
E08	Over Temperature Protection	Waiting for the temperature to decrease
E09	Motor stall	Press the up or down button again to see if the error persists Please replace the motor or reduce the load
RST	Power outage	Reduce the load or check if the power connection wire is loose