

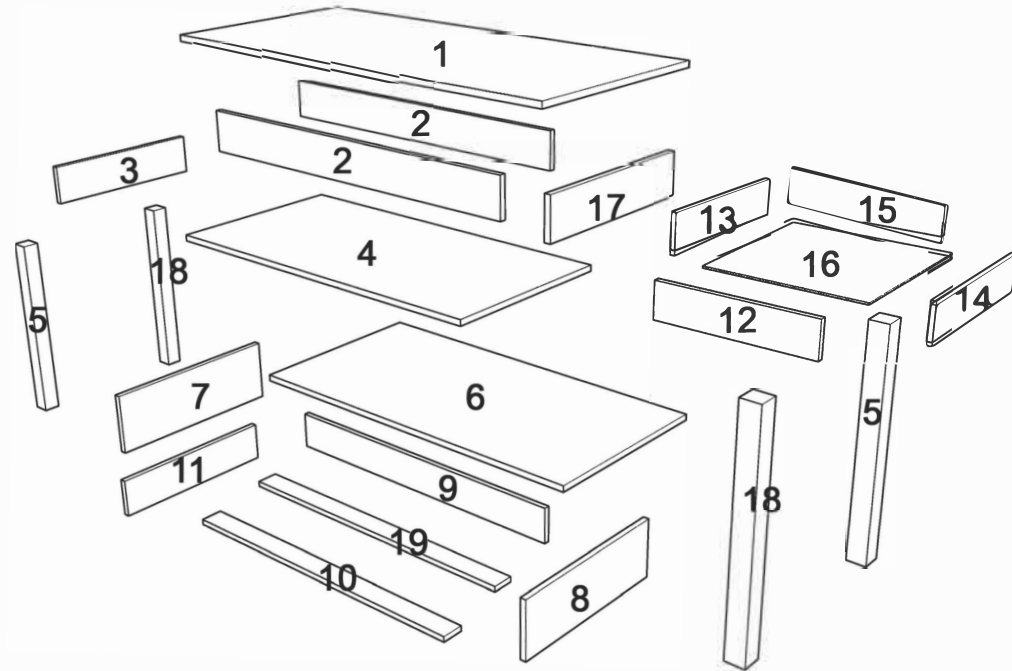









ASSEMBLY INSTRUCTIONS



PARTS LIST



HARDWARE LIST

A		X 32 SETS	B		X 22 PCS
C		X 1 PC	D		X 44 PCS
E		X 1 SETS	F		X 2 SETS
G		X 16 PCS	H		X 2 PCS
I		X 4 PCS	J		X 1 PC

STEP 1

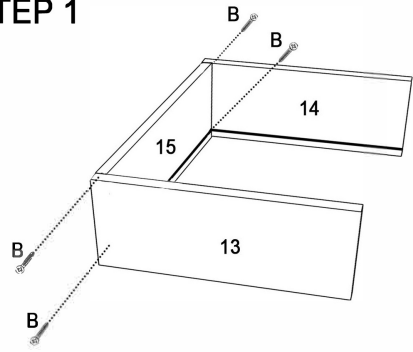

X2

STEP 2

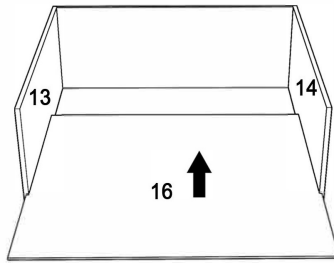

X2

STEP 3

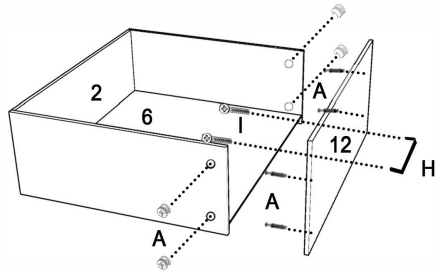

X2

STEP 4

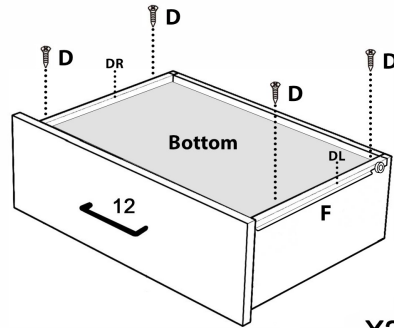

X2

STEP 5

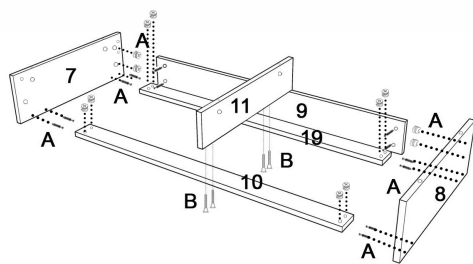

STEP 6

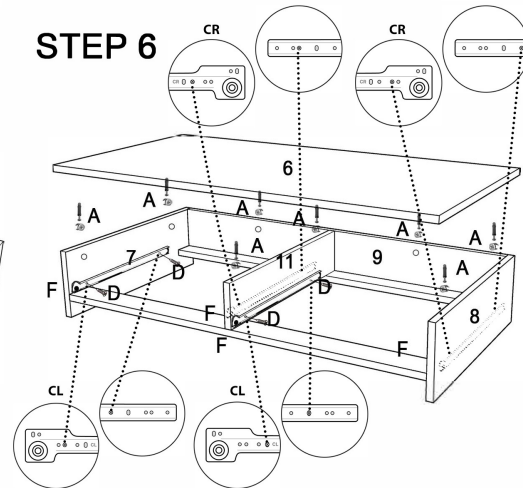

STEP 7

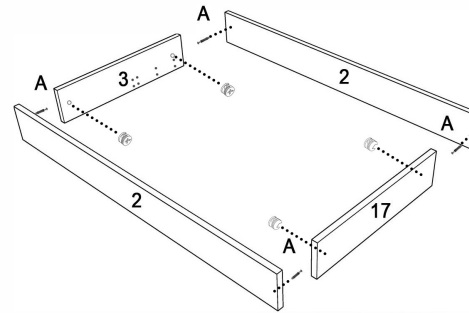

Installation A



STEP 9

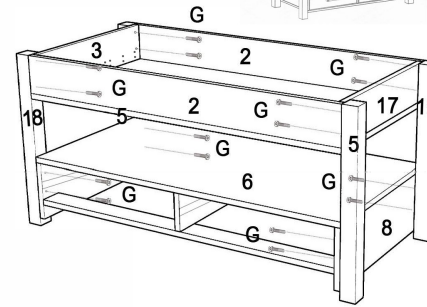

STEP 10 Two people preferred.

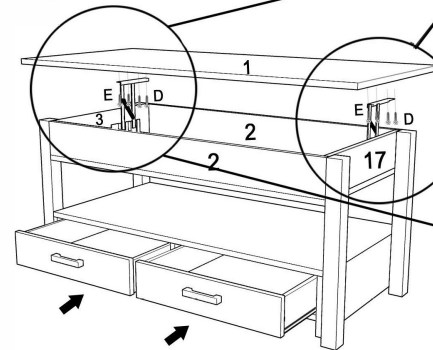

Installation B

Turn around the top section in STEP 9.



STEP 8

